



717 Series End Viewing Target

End-Viewing Target

The **717 Series** paired line target has a pattern which is machine engraved and black-filled on white acetyl plastic. The target is centered within $\pm 0.0005"$ (0.013mm) of the centerline of the plug. This target is very useful when sighting an optical instrument directly on the center point of a tooling reference hole.

Standard plug diameter is 0.250" although as with many of our targets, special variations are available on request.

Please refer to the table below for a listing of target pattern spacings (distance between the target lines) and corresponding order number.

Model	Bi-filar spacing	
717-5-250	0.005"	0.13mm
717-10-250	0.010"	0.25mm
717-15-250	0.015"	0.38mm
717-20-250	0.020"	0.51mm
717-25-250	0.025"	0.64mm
717-30-250	0.030"	0.76mm

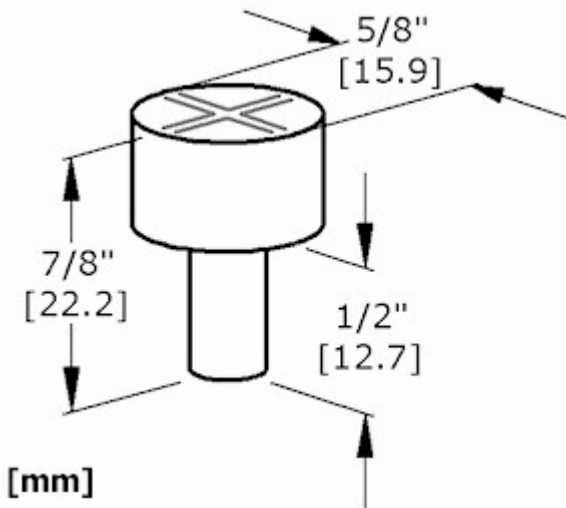

Specifications

Target centering:
 $\pm 0.0005"$ (0.013mm)

Target line width:
0.010" (0.254mm) for targets with line spacings up to and including 0.020".
0.015" (0.381mm) for targets with line spacings above 0.020".

May be used with...

- 740-A Adjustable Floor Target Mount
- Customer supplied fixtures